

# Licross<sup>®</sup> Recessed

750mm

51TL . . . E...

52TL . . . E...

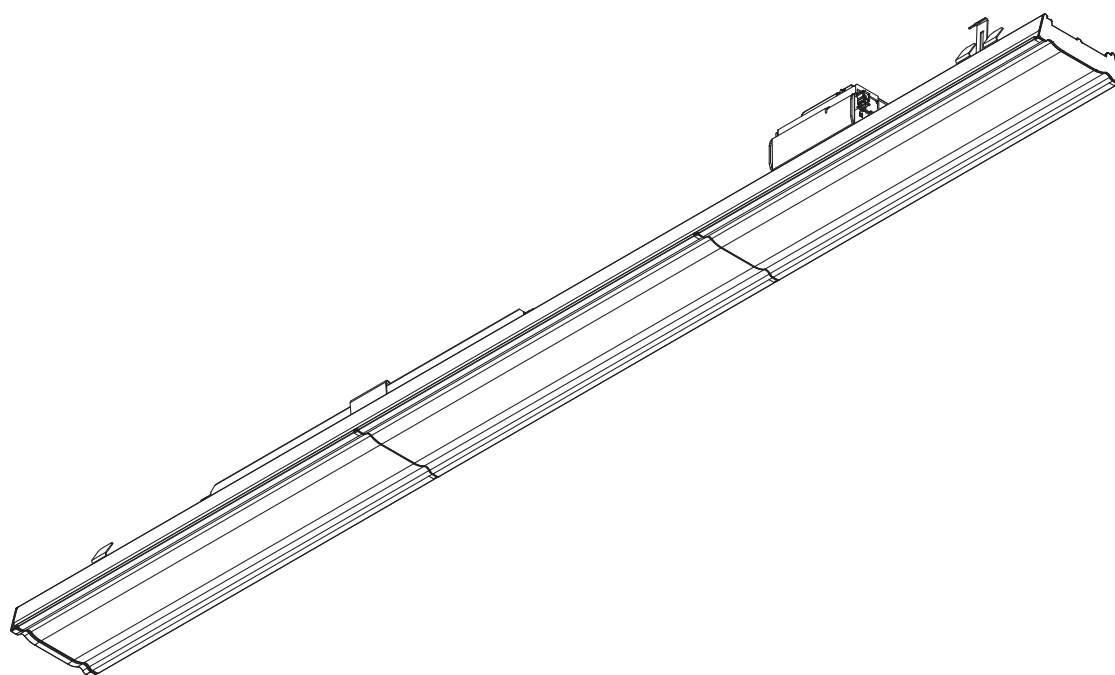

**siteco**

Licross® Recessed - 750mm

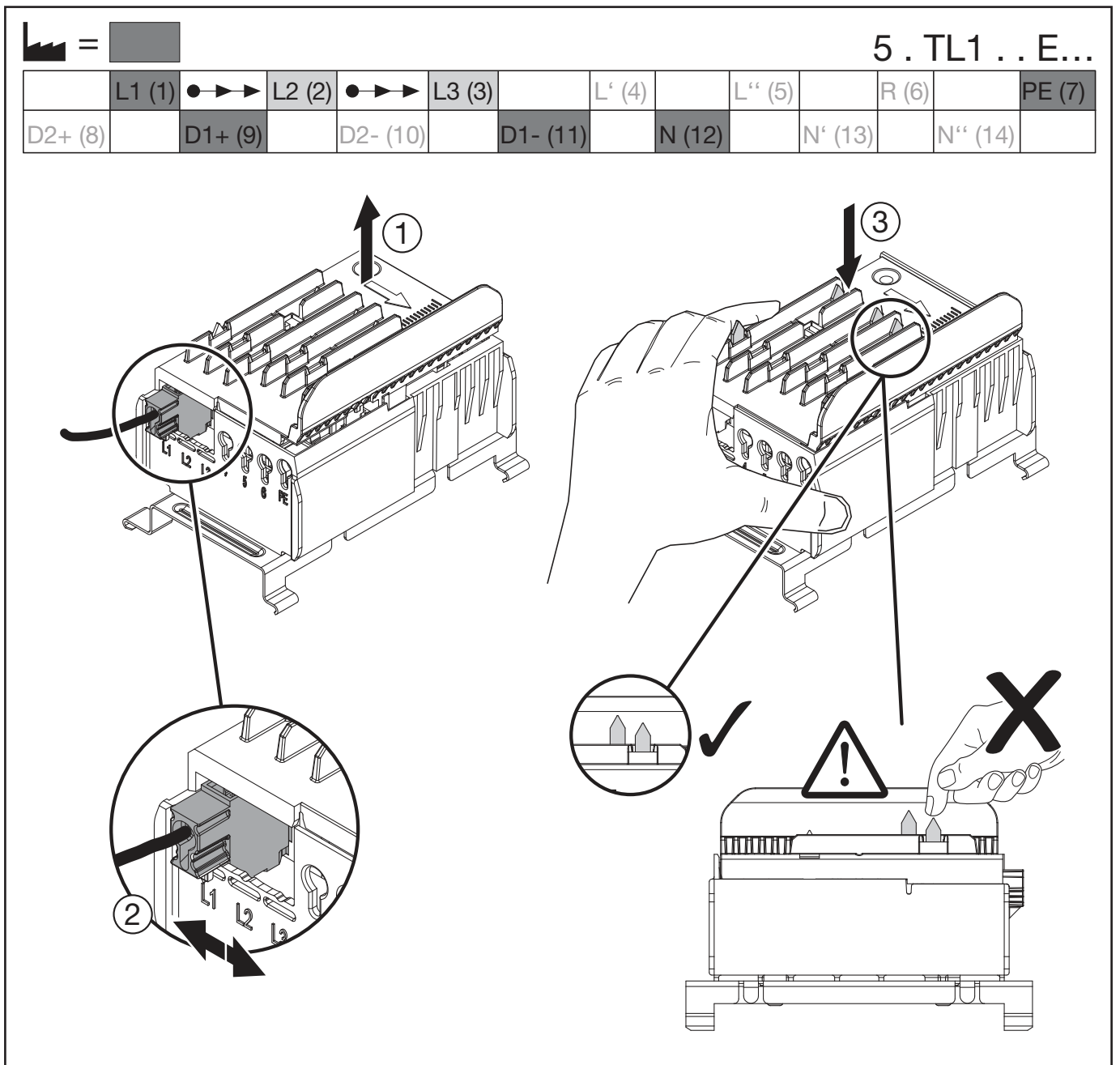
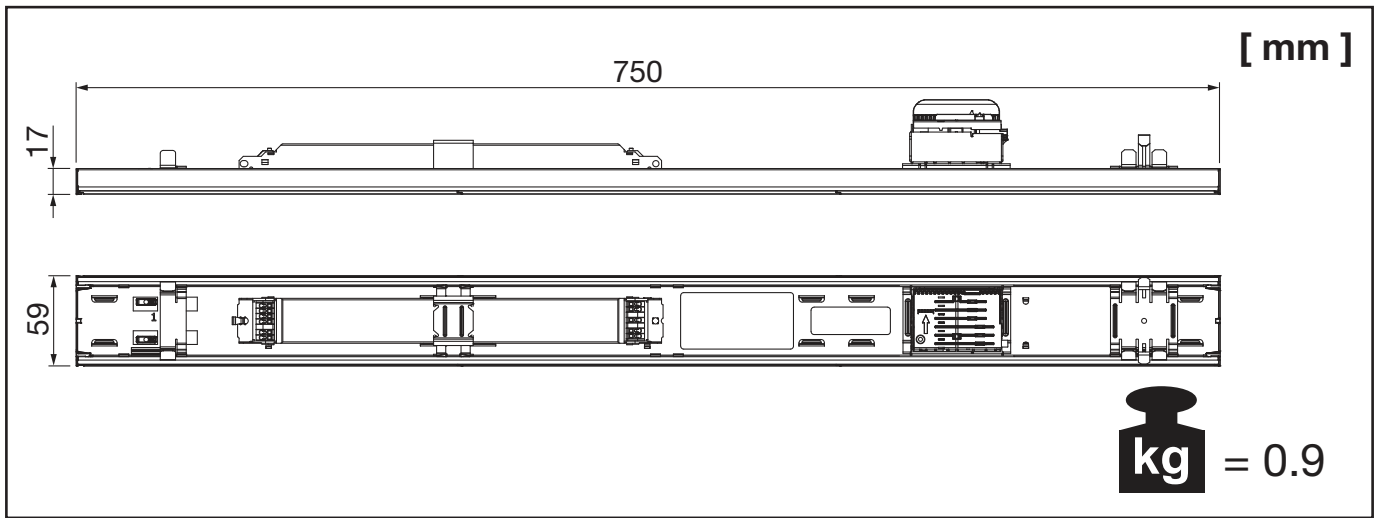

5 . TL1 .. E . . . . D

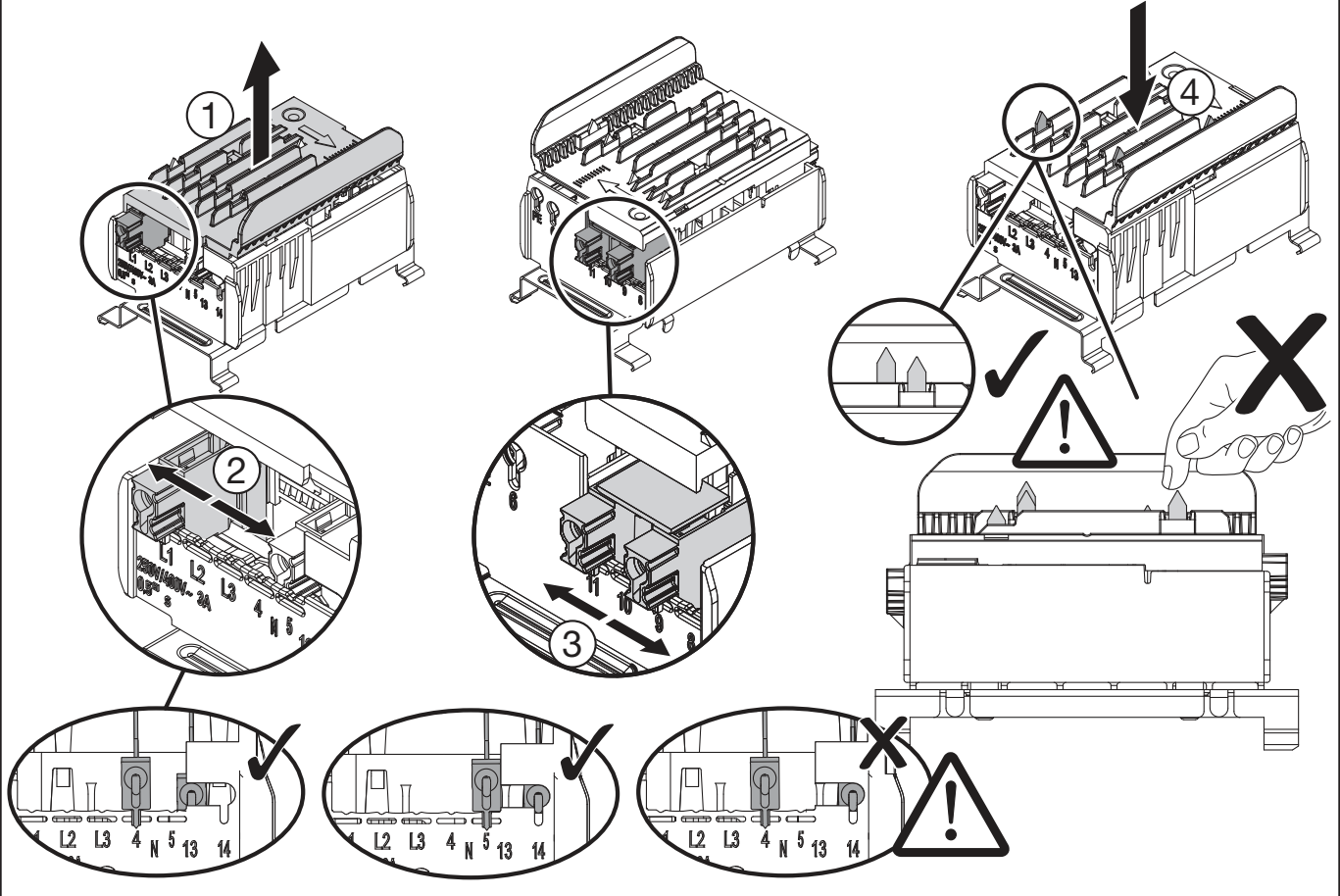
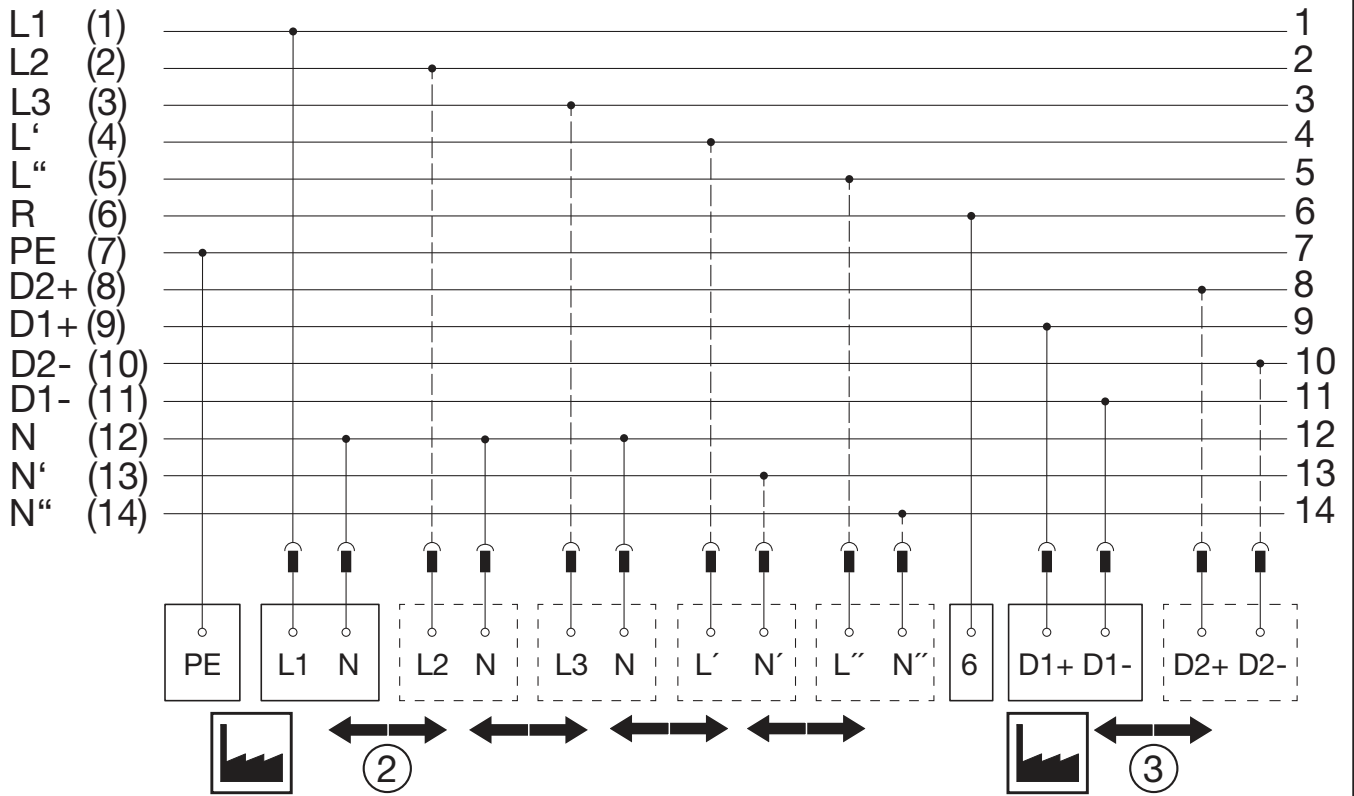

**1** Umgebungstemperatur während der Installation: +5°C...+40°C  
 Ambient temperature during installation:

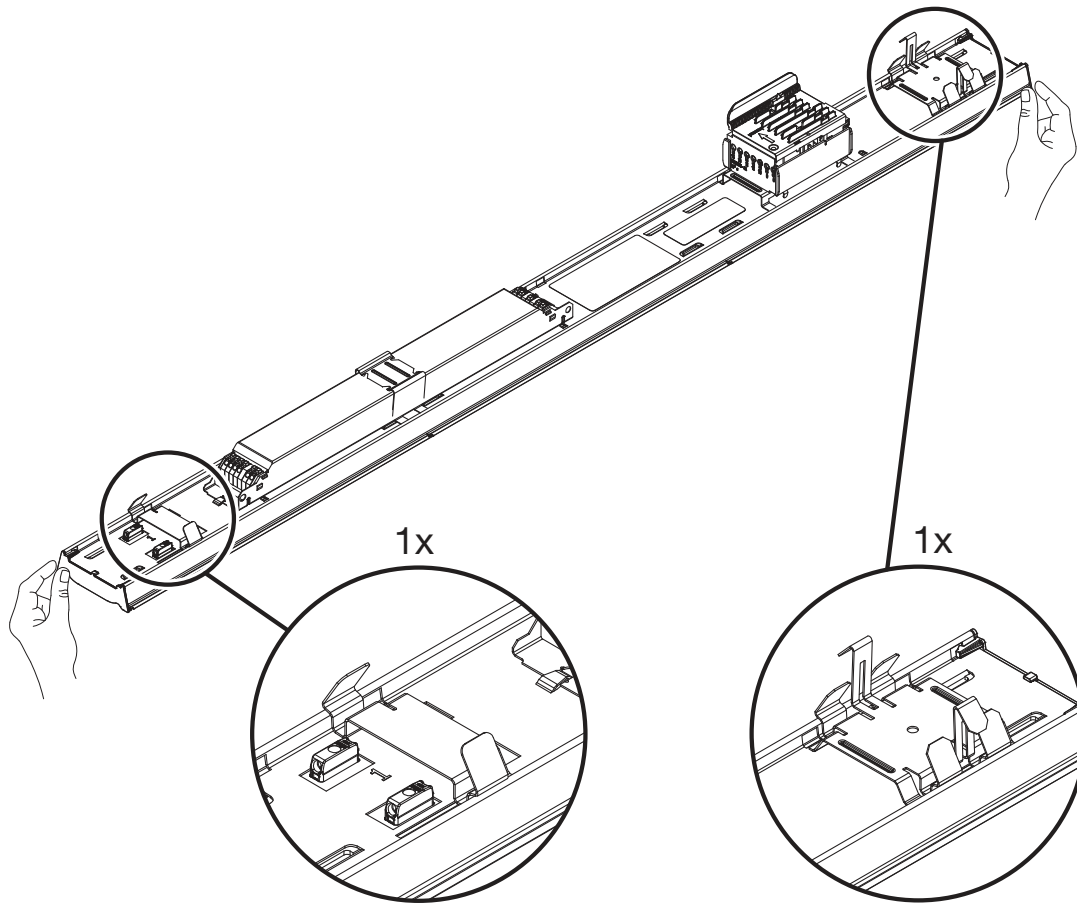

	B10 [A]	B13 [A]	B16 [A]	C10 [A]	C13 [A]	C16 [A]
5 . TL1 .. E ... M	≤15	≤20	≤24	≤25	≤33	≤40
5 . TL1 .. E ... G	≤18	≤23	≤28	≤29	≤38	≤47

Die individuelle Auslegung der Elektroinstallation muss gemäß den Installationsrichtlinien IEC 60364 / DIN VDE 0100 erfolgen. Zudem sind die Einschaltströme, die Abschaltbedingungen für Schutzeinrichtungen (Schleifenimpedanz) und die Einhaltung des max. zulässigen Spannungsfalls zu beachten.

The individual design of the electrical installation must be realized in accordance with the installation guidelines IEC 60364 / DIN VDE 100. In addition, the switch-on currents, the switch-off conditions for protective devices (loop impedance) and compliance with the maximum permissible voltage drop must be observed.

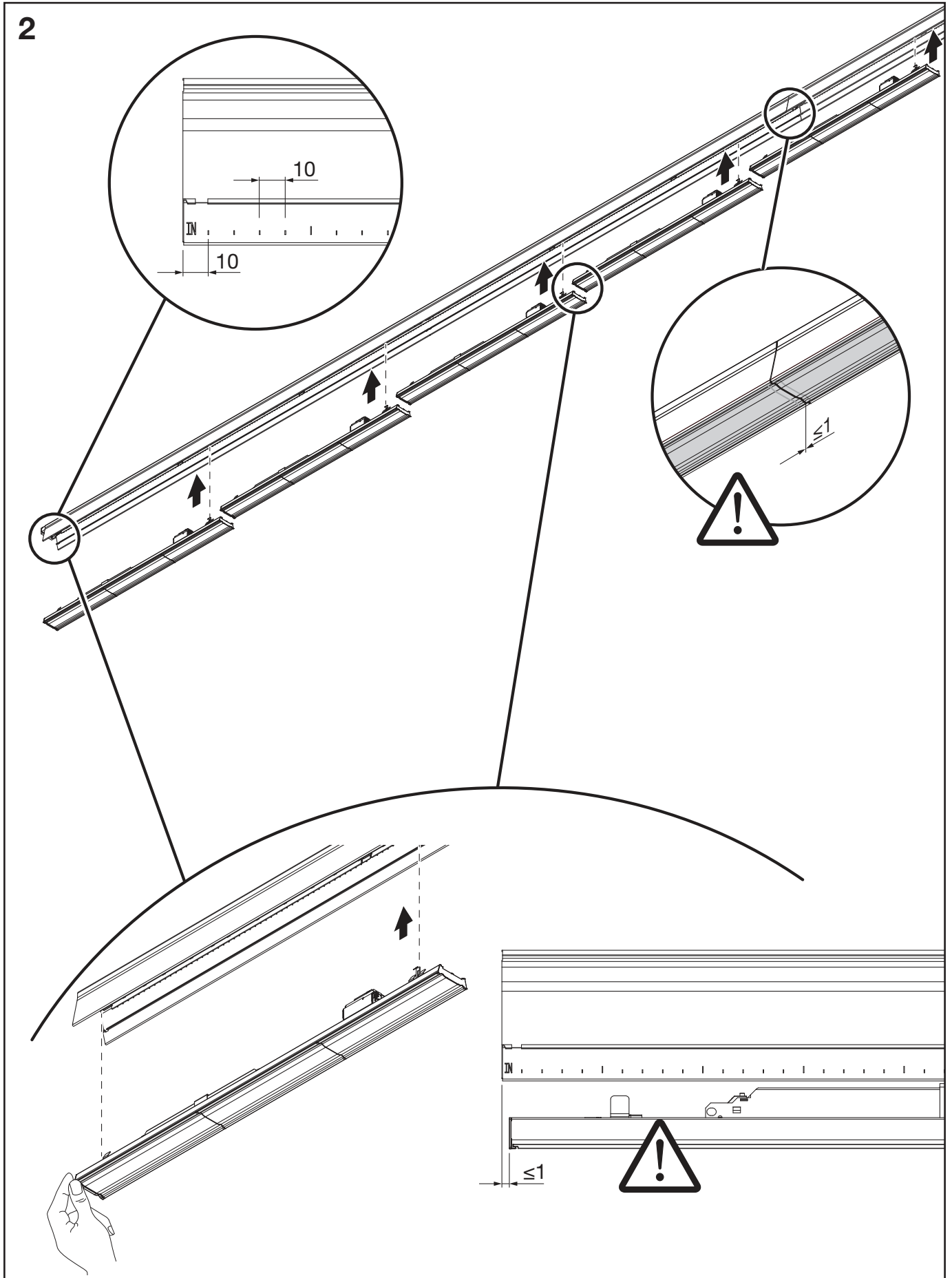

3

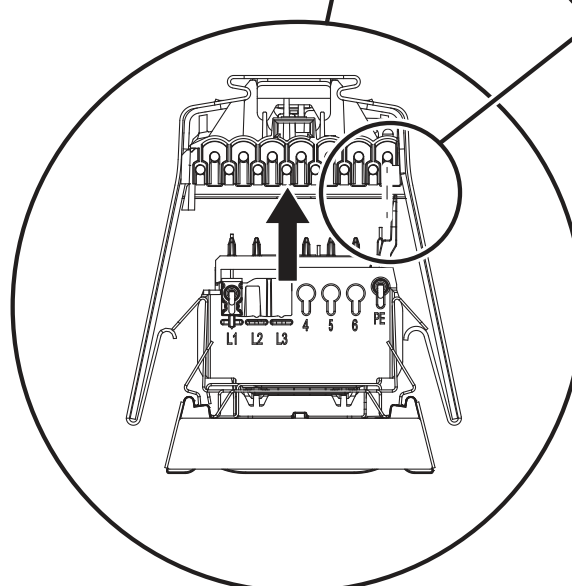
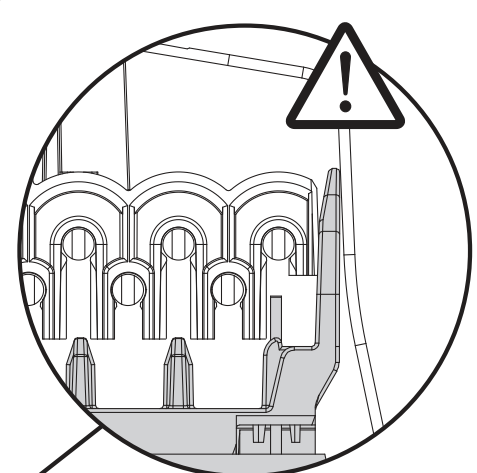
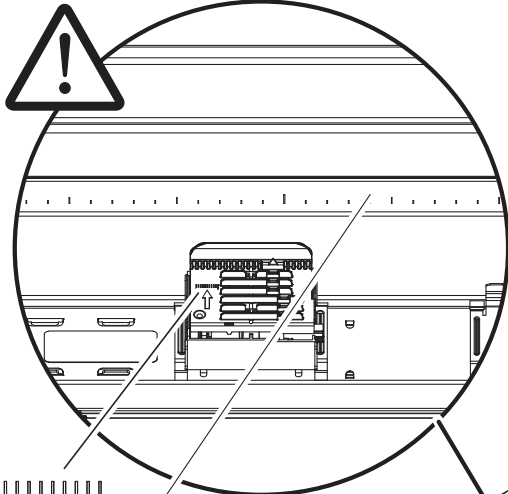
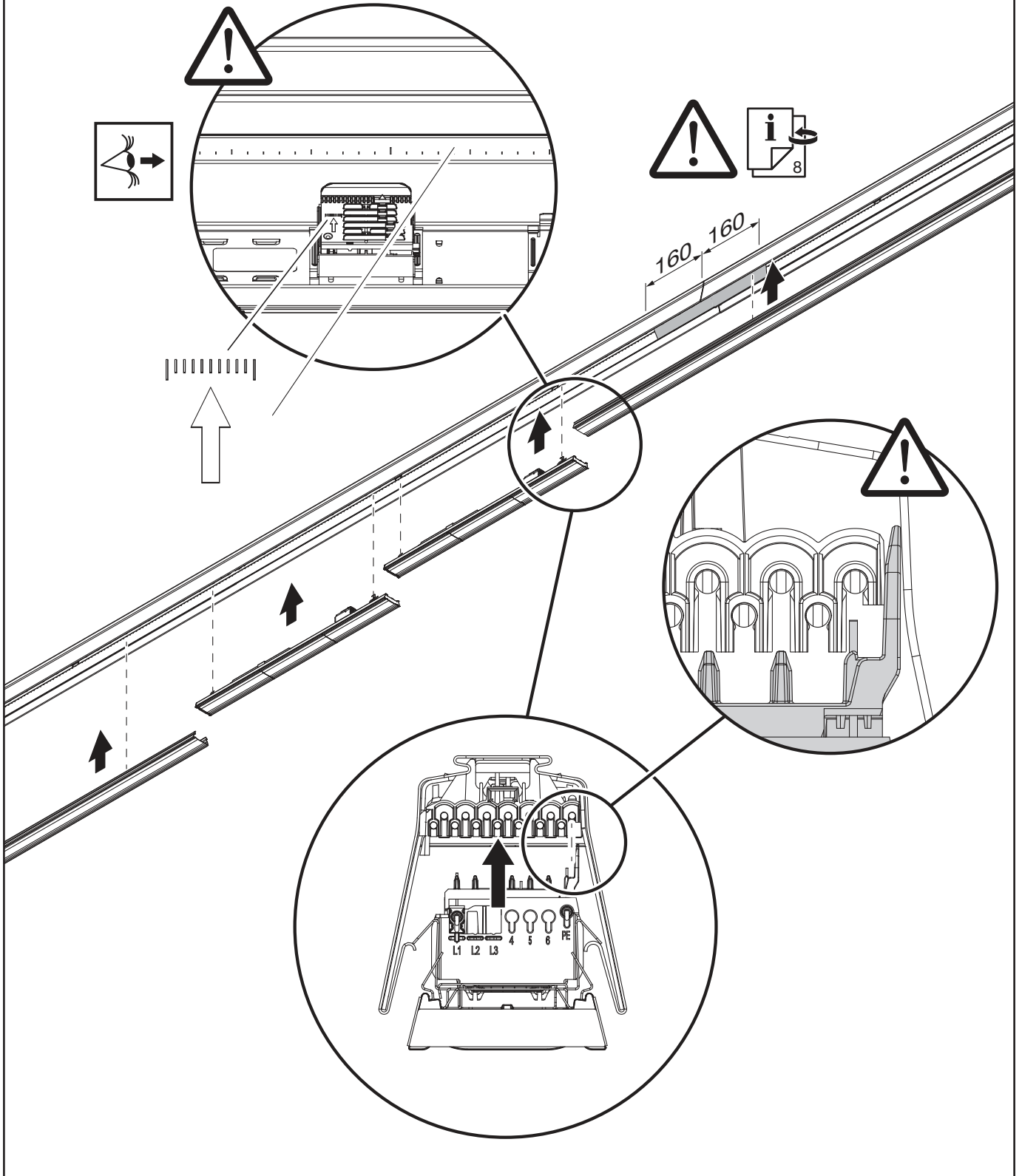

4

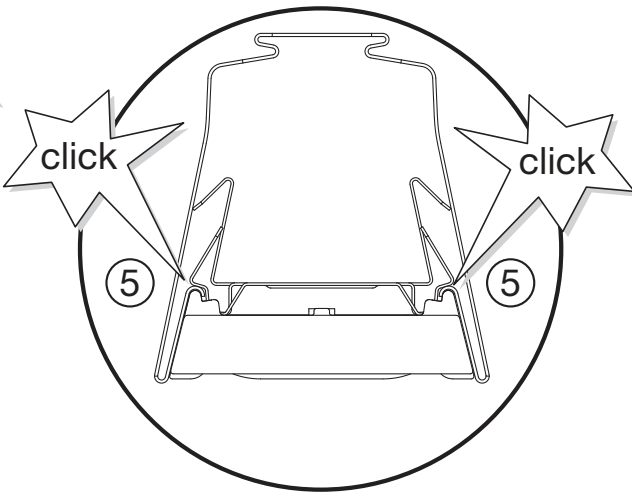
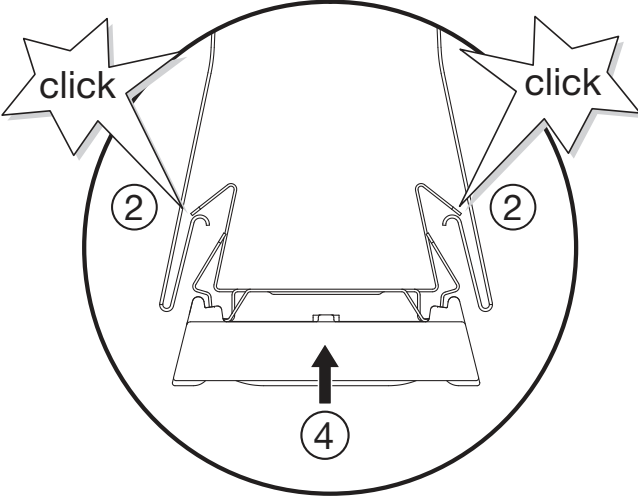
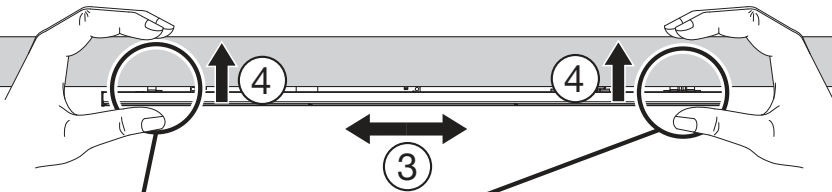
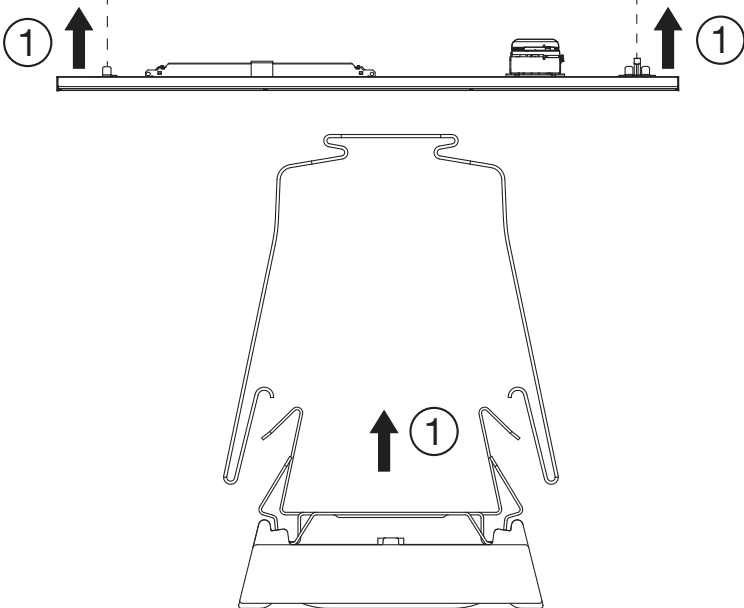

5 . TL14...

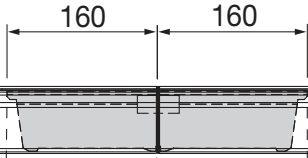
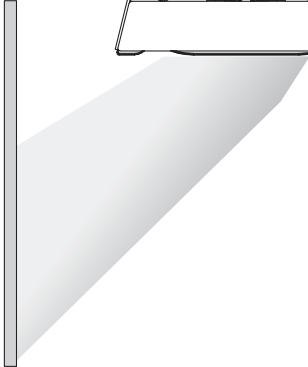
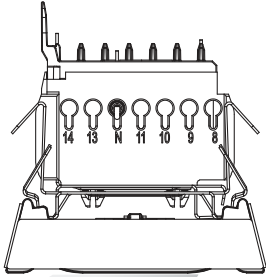
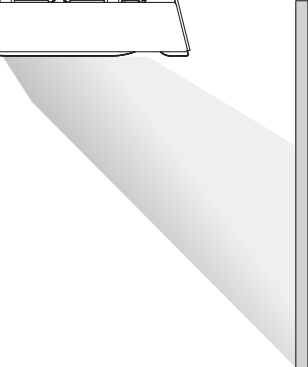
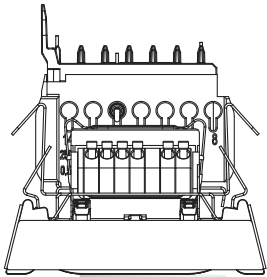



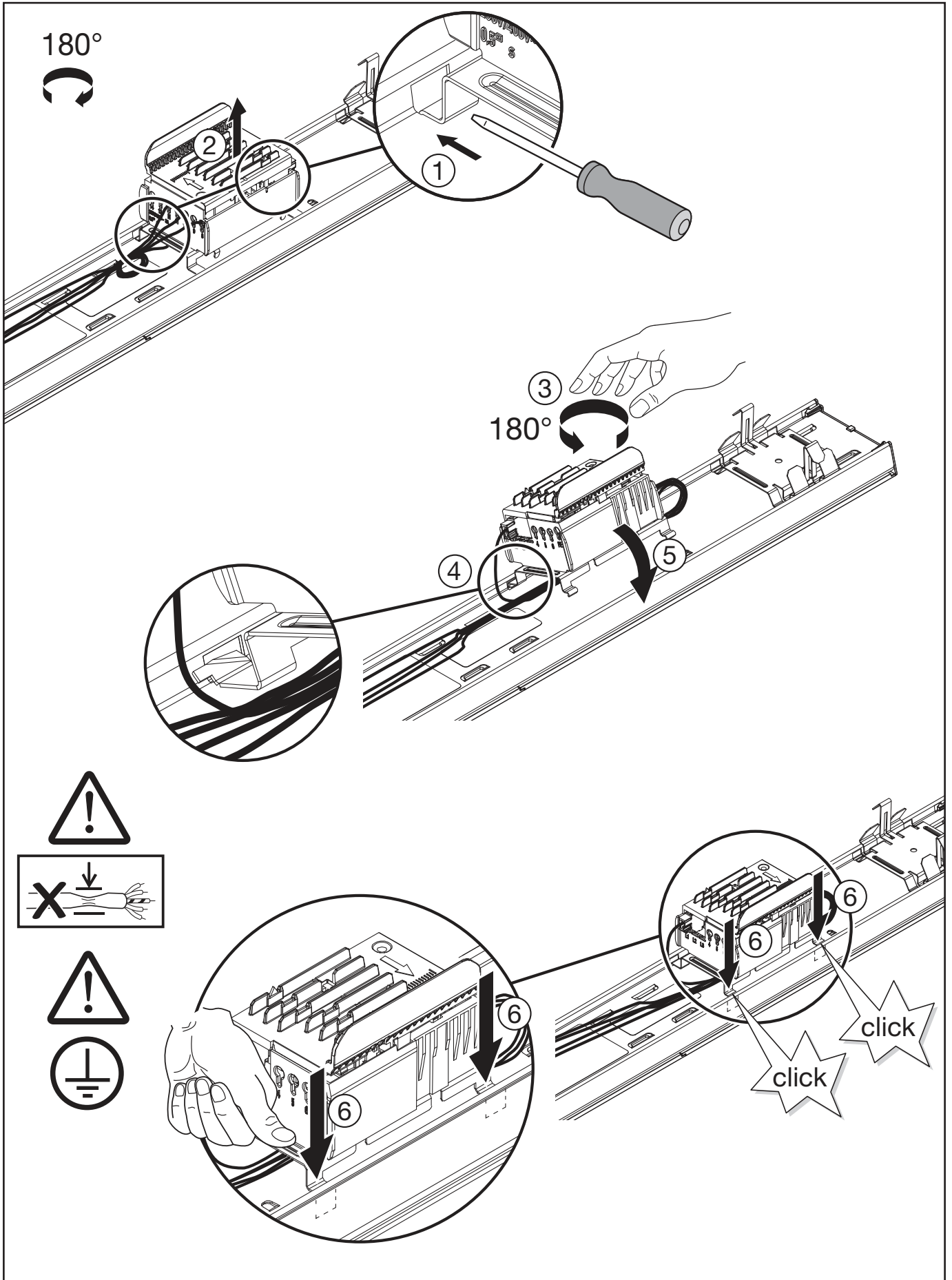

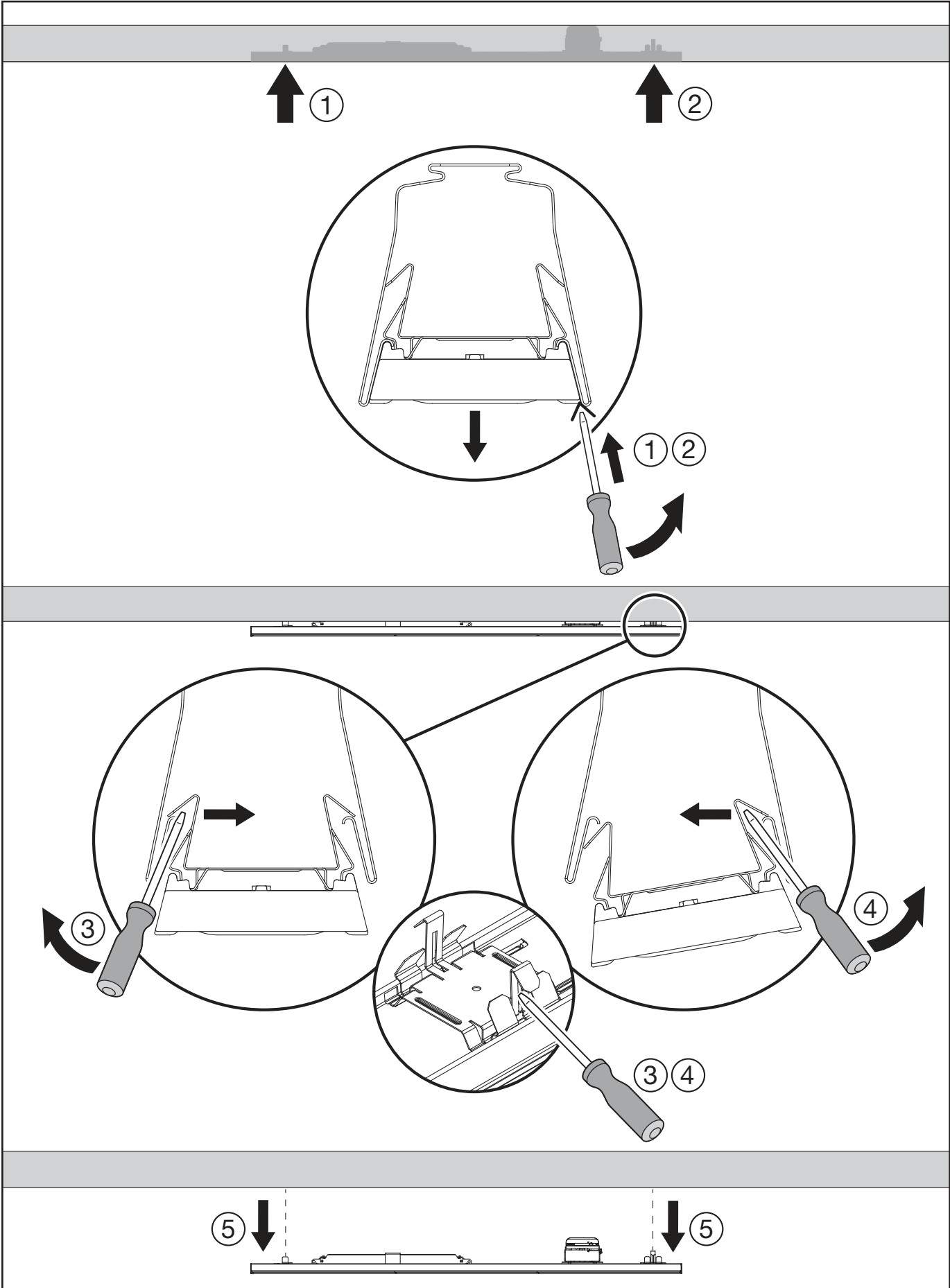

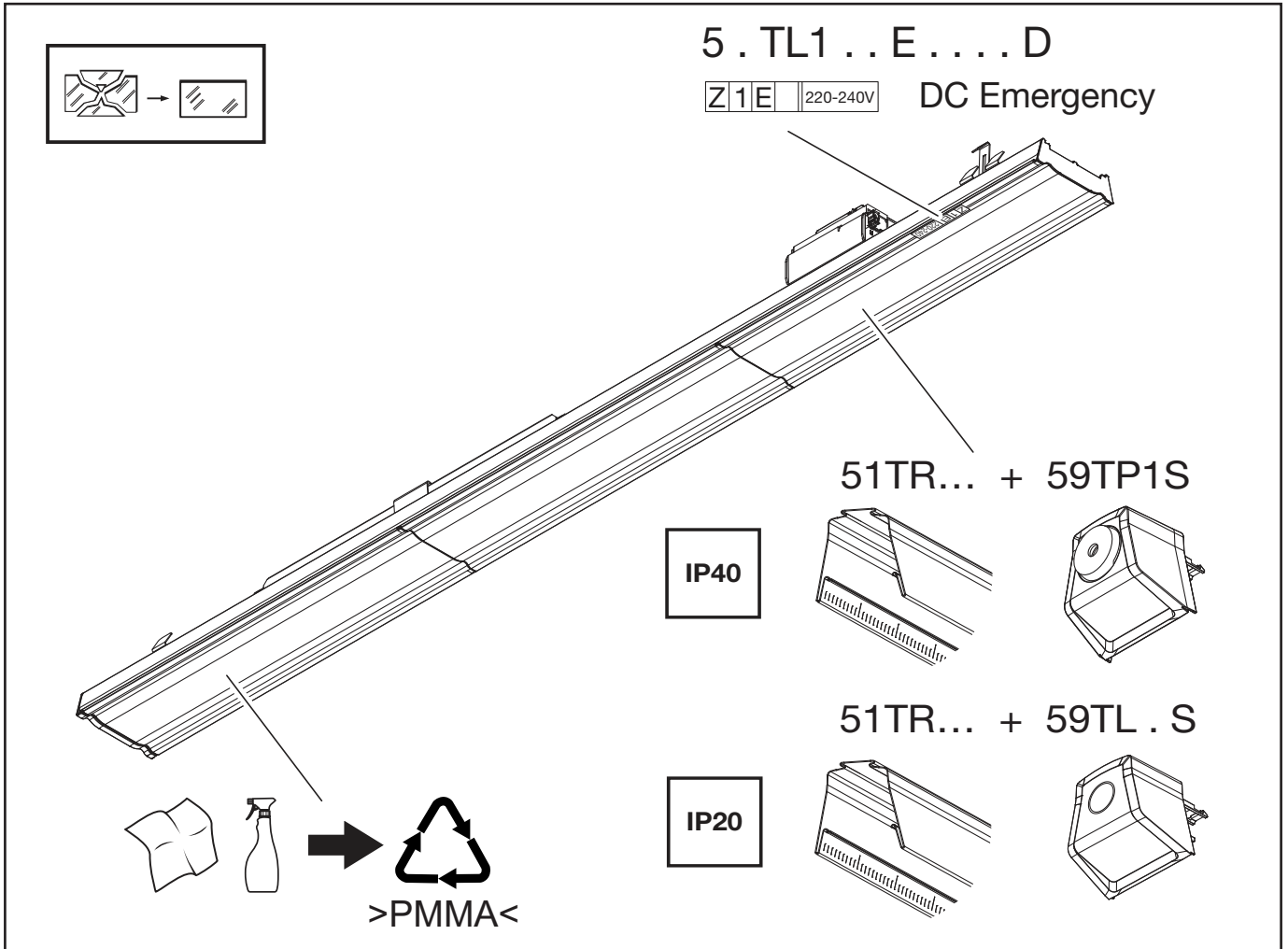

52T . . . . 1...	<b>C</b>	52T . . . . 4 . . . S	<b>B</b>	52T . . . . F...	<b>D</b>	51T . . . . T...	<b>B</b>
52T . . . . 2...	<b>C</b>	52T . . . . 5...	<b>C</b>	51T . . . . 1...	<b>B</b>	51T . . . . A...	<b>C</b>
52T . . . . 3...	<b>C</b>	52T . . . . 6...	<b>C</b>	51T . . . . 2...	<b>B</b>	51T . . . . B...	<b>C</b>
52T . . . . 4 . . . F	<b>C</b>	52T . . . . A...	<b>D</b>	51T . . . . 3...	<b>B</b>	51T . . . . C...	<b>B</b>
52T . . . . 4 . . . L	<b>C</b>	52T . . . . B...	<b>D</b>	51T . . . . 4...	<b>B</b>	51T . . . . D...	<b>B</b>
52T . . . . 4 . . . R	<b>C</b>	52T . . . . C...	<b>D</b>	51T . . . . 5...	<b>B</b>	51T . . . . E...	<b>B</b>
52T . . . . 4 . . . G	<b>B</b>	52T . . . . D...	<b>D</b>	51T . . . . 6...	<b>B</b>	51T . . . . F...	<b>B</b>
52T . . . . 4 . . . M	<b>B</b>	52T . . . . E...	<b>D</b>				

Dieses Produkt enthält eine Lichtquelle der Energieeffizienzklasse B -D.  
This product contains a light source of energy efficiency class B - D.

Die Lichtquelle sowie das Betriebsgerät entsprechen den Anforderungen der Ökodesign-Verordnung (EU) 2019/2020, diese sind gemäß dieser Verordnung austauschbar.  
The light source and control gear comply with the requirements of the Ecodesign Regulation (EU) 2019/2020 and are interchangeable in accordance with this regulation.



+



Ⓓ Zur Verwendung in einer Umgebung, in der keine ungewöhnliche Staubablagerung erwartet wird. Ⓔ For use in an environment in which unusual dust deposits are not expected. Ⓕ Destiné à être utilisé dans un environnement dans lequel il n'y a pas d'accumulation inhabituelle de poussière. Ⓖ Da usare in ambienti in cui non si prevedono depositi di polvere insoliti. Ⓖ Para aplicaciones en un entorno en el cual no se espera una acumulación inusual de polvo. Ⓖ Para uso em ambiente, no qual não se prevê acumulação anormal de poeiras. Ⓖ Για χρήση σε περιβάλλον στο οποίο δεν αναμένεται ασυνήθης συσσώρευση σκόνης. Ⓖ Voor gebruik in een omgeving, waar geen ongebruikelijke stofafzettingen worden verwacht. Ⓖ För användning i en miljö där ingen onormal mängd av damm förväntas. Ⓖ Käytettäväksi ympäristöissä, joissa ei ole odotettavissa epätavallisia pölykertymiä. Ⓖ For bruk i miljøer der det ikke forventes uvanlig mye støv. Ⓖ Til brug i miljøer, hvor der ikke forventes usædvanlig støvaflejring. Ⓖ Pro použití v prostředí, kde se neočekává neobvyklé usazování prachu. Ⓖ Для использования в местах, где сильное оседание пыли не предвидится. Ⓖ Olyan környezetben használandó, ahol nem várható szokatlan porlerakodás. Ⓖ Do użytku w środowisku, w którym nie przewiduje się gromadzenia na oprawie kurzu (pyłu). Ⓖ Na použitie v prostredí, v ktorom sa neočakáva nezvyčajné usadzovanie prachu. Ⓖ Za uporabo v okolju, kjer ni pričakovano neobičajno kopičenje prahu. Ⓖ Olağan dışı toz birikmesi beklenmeyen bir ortamda kullanım içindir. Ⓖ Za uporabu u okolini, u kojoj se ne očekuju neobičajene naslage prašine. Ⓖ Pentru utilizare într-un mediu în care se aşteaptă o acumulare neobişnuită de praf. Ⓖ Предназначени за среда, в която не се очаква необичайно отлагане на прах. Ⓖ Kasutamiseks tolmuvabas keskkonnas. Ⓖ Skirta naudoti aplinkoje, kurioje nesikaupia neįprastos dulkes. Ⓖ Izumantošanai vidē, kurā nav paredzama netipisku putekļu uzkrāšanās. Ⓖ Za upotrebu u okruženju gde se ne očekuje neobičajno velika akumulacija prašine. Ⓖ Для використання в середовищі, в якому незвичне скупчення пилу не очікується. Ⓖ Шаңның қалыпсыз жиналуы болмайтын сыртқы ортада қолдану үшін.

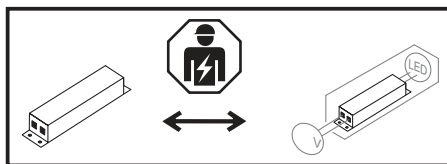
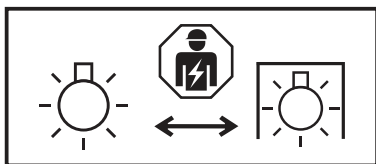

Ⓓ Die in dieser Leuchte enthaltene Lichtquelle und das Betriebsgerät dürfen nur durch den Hersteller, seinem Kundendienst oder einer ähnlich qualifizierten Person ausgewechselt werden. Ⓔ The light source and the control gear contained in this luminaire shall only be replaced by the manufacturer or their service agent or a skilled qualified person.

Ⓖ La source lumineuse et l'appareil de commande contenus dans ce luminaire ne peuvent être remplacés que par le fabricant, son service après-vente ou une personne qualifiée. Ⓖ La sorgente luminosa e l'alimentatore contenuti in questo apparecchio possono essere sostituiti solo dal costruttore, dal suo centro di assistenza o da personale qualificato. Ⓖ La fuente de luz y el equipo de control contenidos en esta luminaria solo deben ser reemplazados por el fabricante, su servicio técnico o una persona cualificada. Ⓖ A fonte de luz e o equipamento de controlo contidos nesta luminária só podem ser substituídos pelo fabricante, pelo seu serviço autorizado ou por pessoa qualificada. Ⓖ Η πηγή φωτός και το σύστημα ελέγχου που περιέχονται σε αυτό το φωτιστικό μπορούν να αντικατασταθούν μόνο από τον κατασκευαστή, τον εξουσιοδοτημένο τεχνικό του ή από κατάλληλα εκπαιδευμένο άτομο. Ⓖ De lichtbron en het voorschakelapparaat in dit armatuur mogen uitsluitend worden vervangen door de fabrikant, diens servicepartner of een vakbekwaam persoon. Ⓖ Ljuskällan och driftdonet i denna armatur får endast bytas av tillverkaren, dess servicepartner eller en fackkunnig person. Ⓖ Tämän valaisimen valonlähteen ja liitäntälaitteen saa vaihtaa vain valmistaja, sen huolto tai pätevä henkilö. Ⓖ Lyskilden og forkoblingen i denne armaturen skal kun skiftes av produsenten, hans servicepartner eller en kvalifisert person. Ⓖ Lyskilden og forkoblingen i dette armatur må kun udskiftes af producenten, dennes servicepartner eller en kvalificeret person. Ⓖ Světelný zdroj a předřadník v tomto svítidle smí vyměnit pouze výrobce, jeho servis nebo kvalifikovaná osoba. Ⓖ Источник света и пускорегулирующую аппаратуру в данном светильнике могут заменять только производитель, его сервисная служба или квалифицированное лицо. Ⓖ A világítóttestben lévő fényforrás és előtetet csak a gyártó, annak szervize vagy képzett személy cserélheti. Ⓖ Źródło światła i zasilacz znajdujące się w tej oprawie mogą być wymieniane wyłącznie przez producenta, jego serwis lub osobę wykwalifikowaną. Ⓖ Svetelný zdroj a predradník v tomto svietidle smie vymieňať len výrobca, jeho servis alebo kvalifikovaná osoba. Ⓖ Svetlobni vir in napajalnik v tej svetilki lahko zamenja le proizvajalec, njegov servis ali usposobljena oseba. Ⓖ Bu armatürdeki ışık kaynağı ve kontrol donanımı yalnızca üretici, yetkili servisi veya yetkin bir kişi tarafından değiştirilebilir. Ⓖ Izvor svjetla i upravljački uređaj u ovoj svjetiljci smiju zamjenjivati samo proizvođač, njegov servis ili kvalificirana osoba. Ⓖ Sursa de lumină și balastul conținute în acest corp de iluminat pot fi înlocuite doar de producător, de serviciul său autorizat sau de o persoană calificată. Ⓖ Светлинният източник и апаратът в това осветително тяло могат да се подменят само от производителя, неговия сервис или квалифицирано лице. Ⓖ Selles valgustis olevat valgusallik ja toiteplokki võib vahetada ainult tootja, tema hoolduspartner või kvalifitseeritud isik. Ⓖ Šiame šviestu ve esantį šviesos šaltinį ir maitinimo įrenginį gali keisti tik gamintojas, jo servisas arba kvalifikuotas asmuo. Ⓖ Šā gaismekļa gaismas avotu ir vadības ierīci drīkst nomainīt tikai ražotājs, viņa serviss vai kvalificēta persona. Ⓖ Izvor svetlosti i upravljački uređaj u ovoj svetiljci smeju da zamene samo proizvođač, njegov servis ili kvalifikovano lice. Ⓖ Джерело світла та пускорегулювальний апарат у цьому світильнику можуть замінювати лише виробник, його сервіс або кваліфікована особа. Ⓖ Осы шамдағы жарық көзін және басқару құрылғысын тек өндіруші, оның сервистік өкілі немесе білікті адам ғана ауыстыра алады.



5MA14-265906\_ac  
21.10.2025 / KIN

Siteco GmbH  
Georg-Simon-Ohm-Straße 50  
83301 Traunreut, Germany  
mail: technicalsupport@siteco.de  
Phone: +49 8669 / 33-844  
www.siteco.com