

**Order No.:** 5XA54000XBL | **GTIN (EAN):** 4050737971421

**Product description:** Mod540,shield,alu,wh

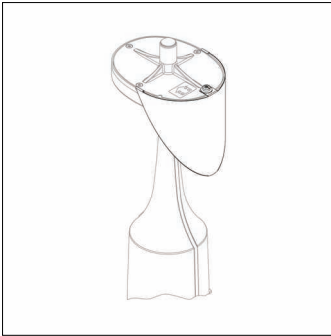

Module 540; shield for rear shielding of aluminium, pure white (RAL 9010);  
height: 200mm; packaging unit: 1 piece

Wt. (kg): 0.1  
GTIN (EAN): 4050737971421

Order No.: 5XA54000XBL | GTIN (EAN): 4050737971421

Detailed technical description: Mod540,shield,alu,wh

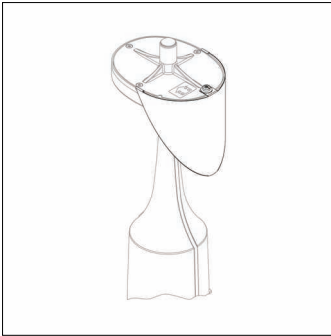

#### Key data

- Product type: shield
- Product name: Module 540
- Order No.: 5XA54000XBL

#### Lighting technology | Lamps | Control gear

#### Component 1

#### Lighting technology:

- Glare reduction: rear shielding of aluminium, pure white (RAL 9010)

#### Dimensions, Weight

- Height: 200mm
- Weight: 0.1kg