

Order No.: 5XA5273ER14H000032 | GTIN (EAN): 4058352564929

Product description: CL-Plus,ST1.2a,1470lm830,D4i,Slb



City-Light Plus, mast luminaire, Module 540 Plus, primary light control with 3 zone faceted reflector, of plastic, silver coated, highly specular, structured, primary optical cover: cover, of PMMA, transparent, light distribution: ST1.2a, light emission: direct distribution, primary light characteristic: asymmetric, installation type: post-top, LED, High Power LED, rated luminous flux: 1.470lm, luminous efficacy: 104lm/W, light colour: 830, colour temperature: 3000K, control gear: ECG Smart Interface, control: overheat protection, digital communication interface, time-dependent luminous flux control, flexible luminous flux parameterisation, presetting dimming logarithmic, with terminal, 6-pole, max. 2.5mm<sup>2</sup>, mains connection: 230..240V, AC, 50/60Hz, start of lifetime: 14W, end of service life: 15W, reduction: 8W, luminaire housing, upper part, of glass-fibre reinforced polyester, coated, Siteco® metallic grey (DB 702S), diameter: 750mm, height: 590mm, spigot size: d x l = 76 x 70mm (post-top) | with reducer (optional accessory) 60 x 70mm, post-top mast mounting element, of diecast aluminium, coated, Siteco® metallic grey (DB 702S), Module 540 Plus, traffic white (RAL 9016), Smart Interface below, protection rating (complete): IP65, insulation class (complete): insulation class II (safety insulation), certification: CE, ENEC, VDE, packaging unit: 1 piece



|             |               |
|-------------|---------------|
| Lamps:      | LED           |
| Wt. (kg):   | 10.5          |
| GTIN (EAN): | 4058352564929 |

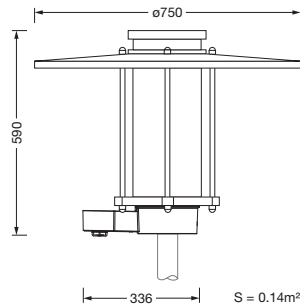

Order No.: 5XA5273ER14H000032 | GTIN (EAN): 4058352564929

Detailed technical description: CL-Plus,ST1.2a,1470lm830,D4i,SIb



### Key data

- Product type: mast luminaire
- Product name: City-Light Plus
- Order No.: 5XA5273ER14H000032

### Lighting technology | Lamps | Control gear

#### Component 1

#### Lighting technology:

- Light control: 3 zone faceted reflector of plastic, silver coated, highly specular
- Cover: cover, transparent
- Light distribution: ST1.2a
- Beam angle: wide distribution
- Symmetry: asymmetric distribution
- Light emission: direct distribution

#### Lamps:

- Lamps: with High Power LED, LED
- Rated luminous flux: 1470lm
- Luminous efficacy: 104lm/W
- Colour temperature: 3000K
- Colour rendering index: CRI > 80
- Light colour: 830
- SDCM (Standard Deviation of Colour Matching): MacAdam ≤ 5 SDCM (initial)
- Rated input power begin service life: 14
- Rated input power end service life: 15
- Rated input power at 50% lumin. flux: 8

#### Operating device:

- Control gear: ECG Smart Interface
- Control: D4i, Smart Interface below
- Equipment: overheat protection, digital communication interface, time-dependent luminous flux control, flexible luminous flux parameterisation, presetting dimming logarithmic

#### Certificates, Standards

- Protection rating: IP65
- Insulation class: insulation class II (safety insulation)
- Certification, designation: CE, ENEC, VDE

### Material, Colour

- luminaire housing, upper part: glass-fibre reinforced polyester, coated, Siteco® metallic grey (DB 702S)
- Colour specification: Siteco® metallic grey (DB 702S)
- post-top mast mounting element: diecast aluminium, coated, Siteco® metallic grey (DB 702S)
- Colour specification: Siteco® metallic grey (DB 702S)
- Colour specification: traffic white (RAL 9016)
- Cover: cover of PMMA

### Mounting

- Mounting method, mounting location: post-top, on mast

### Electrical connection

- Connection: terminal, 6-pole, max. 2.5mm<sup>2</sup>
- Nominal voltage: 230..240V, 50/60Hz, AC
- Surge voltage resistance: 6kV 1.2/50µs

### Dimensions, Weight

- Diameter: 750mm
- Height: 590mm
- Weight: 10.5kg
- Mast spigot: spigot size: d x l = 76 x 70mm (post-top) | with reducer (optional accessory) 60 x 70mm

### Light emission

- Light emission: < 3%

### Service life

- Rated service life: 100000h at AT = 25°C

Order No.: 5XA5273ER14H000032 | GTIN (EAN): 4058352564929

Dimensions: CL-Plus,ST1.2a,1470lm830,D4i,Slb

