

Order No.: 5XA54000XBS | **GTIN (EAN):** 4050737971445

Product description: Mod540,shield,alu,wh

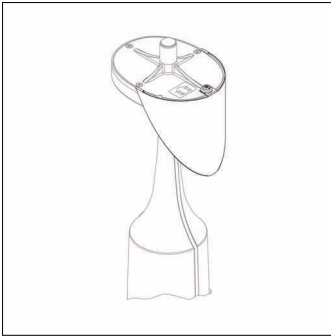

Module 540; shield for rear shielding of aluminium, pure white (RAL 9010);
height: 150mm; packaging unit: 1 piece

Wt. (kg): 0.1
GTIN (EAN): 4050737971445

Order No.: 5XA54000XBS | GTIN (EAN): 4050737971445

Detailed technical description: Mod540,shield,alu,wh

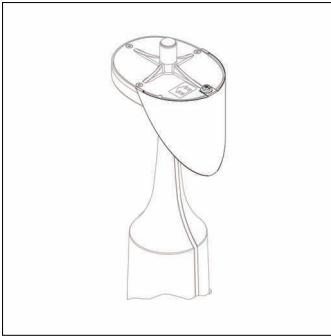

Key data

- Product type: shield
- Product name: Module 540
- Order No.: 5XA54000XBS

Lighting technology | Lamps | Control gear

Component 1

Lighting technology:

- Glare reduction: rear shielding of aluminium, pure white (RAL 9010)

Dimensions, Weight

- Height: 150mm
- Weight: 0.1kg